

Cleaning-friendly construction makes it corrosion-proof and resistant to jets of water

Hygienic and food-neutral due to smooth and abrasion-proof surface

Ergonomic and IP 65 sealed multifunction tiller arm

Powerful thanks to maintenance-free 3-phase AC drive motor

Outstanding cornering thanks to ProTracLink stainless steel coupling unit

Long service life in harsh environments



## EJE i20

### Stainless steel electric pedestrian pallet truck (2,000 kg)

The Jungheinrich EJE i20 stainless steel pallet truck combines the advantages of a stainless steel frame with proven Jungheinrich drive and control technology. The truck is designed for demanding transport operations up to 2000 kg. The EJE i20 is best suited for operation in corrosive and damp environments and satisfies the most stringent hygienic regulations. With these specifications, the truck is ideal for use in the food, chemical and pharmaceutical industries. High-quality V2A stainless steel also offers an abrasion-resistant and smooth surface, even with intensive use: This

prevents dirt deposits, thus preventing the spread of germs and bacteria. The rugged vehicle design is designed to withstand regular high-pressure cleaning and disinfection. Water can flow freely over the continuous bevelled surfaces; special seals inhibit the ingress of fluids into the drive compartment. The design of the multifunctional tiller arm uses encapsulated sensor technology (IP 65) that guarantees maximum protection against breakdown. Contact-free electronic rocker switches as well as an easily accessed crawl speed button allow for ergonomically perfect oper-

ation with every tiller position. High acceleration, speed and efficient braking are the strengths of the powerful drive motor, achievable by the application of innovative 3-phase AC technology. The centrally driven EJE i20 achieves the necessary cornering stability via the Jungheinrich ProTracLink torsion bar made from high-grade stainless steel. Lateral exchange of the battery further ensures the efficient application of the truck in shift operations. All of the above points add to the efficient, safe and fast handling of goods.

# EJE i20

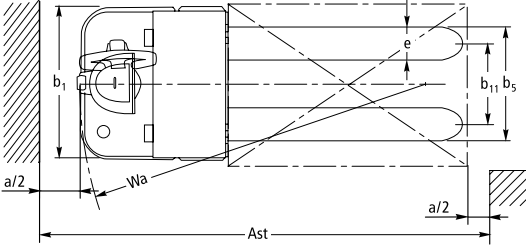
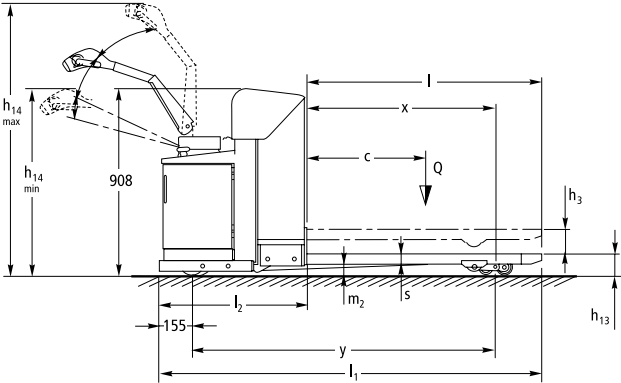

# Technical data in line with VDI 2198

Identification	1.1	Manufacturer (short form)		Jungheinrich
	1.2	Model		<b>EJE i20</b>
	1.3	Drive		Electrics
	1.4	Manual, pedestrian, stand-on, seated, order picker operation		pedestrian
	1.5	Load capacity/rated load	Q t	2
	1.6	Load centre distance	c mm	600
	1.8	Load distance	x mm	913
	1.9	Wheelbase	y mm	1385
	Weights	2.1.1	Net weight incl. battery (see row 6.5)	kg
2.2		Axle load, w. load, front / rear	kg	1074 / 1645
2.3		Axle load, w.o. load, front / rear	kg	574 / 145
Wheels / chassis	3.1	Tyres		Vulkollan
	3.2	Tyre size, at front	mm	Ø 230 x 65
	3.3	Tyre size, at rear	mm	Ø 82 x 66
	3.4	Additional wheels (dimensions)	mm	Ø 125 x 54
	3.5	Wheels, number front/rear (x = driven wheels)		3-1x/4
	3.7	Track width, rear	b <sub>11</sub> mm	390
Basic dimensions	4.4	Lift	h <sub>3</sub> mm	125
	4.9	Height of tiller in drive position min. / max.	h <sub>14</sub> mm	810 / 1124
	4.15	Lowered height	h <sub>13</sub> mm	85
	4.19	Overall length	l <sub>1</sub> mm	1850
	4.20	Length incl. back of forks	l <sub>2</sub> mm	711
	4.21	Total width	b <sub>1</sub> /b <sub>2</sub> mm	740 / 540
	4.22	Fork dimensions	s/e/l mm	56 / 160 / 1150
	4.25	Width over forks	b <sub>5</sub> mm	540
	4.32	Floor clearance centre wheelbase	m <sub>2</sub> mm	35
4.35	Turning radius	W <sub>a</sub> mm	1685	
Performance data	5.1	Travel speed, w. / w.o. load	km/h	5.3 / 5.3
	5.2	Lift speed, w. / w.o. load	m/s	0.046 / 0.06
	5.3	Lower speed, w. / w.o. load	m/s	0.059 / 0.053
	5.7	Gradeability laden/unladen	%	8 / 15
	5.8	Max. gradeability, laden/unladen	%	12 / 15
5.10	Service brake		generated	
Electrics	6.1	Drive motor rating S2 60 min.	kW	1.6
	6.2	Lift motor kW rating at S3 7%	kW	2.2
	6.3	Battery according to DIN 43531/35/36 A,B,C, no		B
	6.4	Battery voltage/nominal capacity K5	V/Ah	24 / 230
	6.5	Battery weight	kg	220
	6.6	Energy consumption according to VDI cycle	kWh/h	0.5
Misc.	8.1	Type of drive control		AC SpeedControl

# Benefit from the advantages



Ready for battery changing: open battery cover and removed side panel



Ergonomic tiller with intuitive buttons



Excellent service access

## 'Hygienic design'

- Smooth and corrosion-free surface is food-neutral due to dirt resistance and the spread of germs and bacteria.
- Stainless steel surfaces offer no risk of material abrasion during production.
- Closed fork section ensures hygienic separation of the load wheels and the goods to be carried.
- Conforms to the EU directive for food-stuff hygiene.

## Easy clean design

The whole truck is extremely easy to clean and is designed for daily operation in damp and wet areas:

- Bevelled surfaces allow water to flow over them with ease.
- Encapsulated multi-function tiller arm control head (IP 65) with encapsulated contactless sensor technology safeguards against high pressure cleaning and disinfection.
- Robust seals protect drive and control components.
- Strong overlapping battery compartment hood protects the battery against the penetration of cleaning fluids.

## High quality materials for demanding applications

The use of material suited to the application guarantees a high reliability and long life:

- Surfaces made from high quality stainless steel reliably prevent corrosion.
- Battery in plastic protective carrier, installed on slide rails.
- All controls are sealed and corrosion proof.

## Work ergonomically

The new-generation multifunctional tiller arm perfectly meets the ergonomic demands of the operator.

- Clear colour coding and buttons with countersunk/raised designs for intuitive operation.
- Grip angle to suit the hand position of the operator.
- Crawl speed button underneath the tiller arm for easy access and travelling with the tiller upright.
- Rocker switch for consistent operation in all tiller positions.
- Centrally positioned large emergency stop button with safety guard.
- 3-colour LED battery monitor shows the battery discharge status at all times.

- Battery exchange from above or side with plastic sliders.

## Optimal cornering

The spring mounted and damped support wheels connected by the torsion bar suspension system "ProTracLink" made from stainless steel, ensure safe operation, a reduction in wear and high stability in every travel situation. Support is automatically distributed equally over all wheels during straight travel or concentrated on the outer support wheel during cornering.

## Innovative 3rd Generation AC technology

Jungheinrich 3rd Generation AC technology motors offer high performance and at the same time, reduce operating costs:

- Powerful acceleration.
- Higher efficiency with excellent energy consumption.
- Faster travel direction change without delay.
- No carbon brushes – the drive motor is maintenance free.
- 2 year guarantee on the drive motor.

Jungheinrich Singapore Pte Ltd

14 Kwong Min Road  
Singapore 628715  
Tel.: +65 6558 7600  
Fax: +65 6558 7611

info@jungheinrich.com.sg  
www.jungheinrich.com.sg

The German production facilities in Norderstedt and Moosburg are certified. **ISO 9001**  
**ISO 14001**

Jungheinrich fork lift trucks meet European safety requirements.



**JUNGHEINRICH**  
Machines. Ideas. Solutions.